

Place this manual in the Toaster section of your **Equipment Manual**.
Manufactured exclusively for
McDONALD'S®

BY
A.J. ANTUNES & CO.
180 KEHOE BLVD.
CAROL STREAM, ILLINOIS 60188, U.S.A.
PHONE: 1-630-784-1000
TOLL FREE: 1-877-392-7854 (USA Only)
FAX: 1-630-784-1650
www.ajantunes.com

A.J. Antunes & Co.



MT-12

Scan with mobile device or enter URL for product and service information.

<http://tiny.cc/ajaMT12>



TABLE OF CONTENTS

Owner Information	2	Operation	8
General	2	Hi-Limit Reset Button	10
Warranty Information	2	Maintenance	10
Service/Technical Assistance	2	Maintenance Schedule	10
Important safety information	3	Function of Diagnostic LEDs	12
Specifications	5	Troubleshooting	13
Electrical Ratings.....	5	Replacement parts	16
Electrical Cord & Plug Configurations	5	Wiring Diagrams	19
Dimensions	6	NOTES	20
Installation	7		
Unpacking.....	7		
Location	7		

IMPORTANT

Keep these instructions for future reference. If the unit changes ownership, be sure this manual accompanies the equipment.

LIMITED WARRANTY

The Antunes Food Service Equipment Division of A.J. Antunes & Co. provides the following limited warranty to the original purchaser of all McDonald's Equipment. All components are warranted against defects in the material and workmanship for a period of two (2) years from date of original installation.

If any part becomes defective during period of this Warranty, Antunes Food Service will pay negotiated straight time labor costs to an Authorized Service Agent to replace the part, plus travel expenses up to 50 miles/80 km, 1 hour each way (100 miles/160 km, 2 hours round trip).

WARRANTY EXCLUSIONS

- The cost of Installation.
- Equipment that has been damaged due to shipment. Purchaser should make damage claim directly upon carrier.
- Alteration, misuse, abuse.
- Improper storage or handling.
- Improper maintenance.
- Failure to follow proper Installation instructions, including electrical connection.
- Improper or unauthorized repairs.
- Scheduled Maintenance procedures as outlined in your MRC Card.
- This Warranty does not cover Consumable items.
- Water pressure problems or contamination problems such as foreign material in water lines or inside solenoid valves due to an incoming water source.
- Overtime or Holiday charges.
- Mileage over 50 miles/80 km (100 miles/160 km round-trip), or travel time over two (2) hours.
- Freight, foreign, excise, municipal or other sales or use taxes.
- Consequential damages such as loss of profit, loss of time, the cost of repairing or replacing other property which is damaged, or any other incidental damage of any kind.

Antunes Food Service reserves the right to make changes in design or add improvements on any products. The right is always reserved to modify Equipment because of factors beyond our control and government regulation. Changes to Equipment do not constitute a warranty charge. This warranty is exclusive and is in lieu of all other warranties, expressed or implied, including any implied warranty of merchantability or fitness for a particular purpose, each of which is expressly disclaimed. The remedies described above are exclusive, and in no event shall A.J. Antunes & Co. or any of its Divisions be liable for special consequential or incidental damages for the breach or delay in the performance of this warranty.

This manual is for the exclusive use of licensees and employees of McDonald's Systems, Inc. © McDonald's Corporation All Rights Reserved

MUFFIN TOASTER MT-12

OWNER INFORMATION

General

The Muffin Toaster Model MT-12 is designed to toast 6 full English muffins (12 halves) at one time. A temperature sensing solid state control measures the internal temperature of the toaster and adjusts the toasting time automatically to toast muffins faster during heavier use. The toaster signals the operator with an audible beep and a ready light when muffins are ready.

The toaster is capable of producing up to 324 muffins per hour. 6 muffin halves or less is a partial load and 7–12 muffin halves is a full load.

To conserve energy, when the toasting chamber is empty, the toaster idles at 600 watts. This represents a 75% reduction in operational power consumption.

This manual provides the safety, installation, and operating procedures for the unit. We recommend that all information contained in this manual be read prior to installation and operation.

This unit is manufactured from the finest materials available and is assembled to Roundup's strict quality standards. It has been tested at the factory to ensure dependable trouble-free operation.

Warranty Information

Please read the full text of the Limited Warranty in this manual.

If the unit arrives damaged, contact the carrier immediately and file a damage claim with them. Save all packing materials when filing a claim. Freight damage claims are the responsibility of the purchaser and are NOT covered under warranty.

The warranty does NOT extend to:

- Damages caused in shipment or damage as result of improper use.
- Installation of electrical service.
- Normal maintenance as outlined in this manual.
- Malfunction resulting from improper maintenance.
- Damage caused by abuse or careless handling.
- Damage from moisture into electrical components
- Damage from tampering with, removal of, or changing any preset control or safety device.

Service/Technical Assistance

If you experience any problems with the installation or operation of your unit, contact your local Roundup Authorized Service Agency.

Fill in the information below and have it handy when calling your Authorized Service Agency for assistance. The serial number is on the specification plate located on the rear of the unit.

Purchased From: _____

Date of Purchase: _____

Model No.: _____

Serial No.: _____

Mfg. No.: _____

Refer to the service agency directory packaged with your manual and fill in the information below:

Authorized Service Agency

Name: _____

Phone No.: _____

Address: _____

Use only genuine Roundup replacement parts in this unit. Use of replacement parts other than those supplied by the manufacturer will void the warranty. Your Authorized Service Agency has been factory trained and has a complete supply of parts for this toaster.

You may also contact the factory at **1-630-784-1000** if you have trouble locating your Authorized Service Agency.

IMPORTANT SAFETY INFORMATION

Throughout this manual, you will find the following safety words and symbols that signify important safety issues with regards to operating or maintaining the equipment.



GENERAL WARNING. Indicates information important to the proper operation of the equipment. Failure to observe may result in damage to the equipment and/or severe bodily injury or death.



GENERAL CAUTION. Indicates information important to the proper operation of the equipment. Failure to observe may result in damage to the equipment.



ELECTRICAL WARNING. Indicates information relating to possible shock hazard. Failure to observe may result in damage to the equipment and/or severe bodily injury or death.



HOT SURFACE WARNING. Indicates information important to the handling of equipment and parts. Failure to observe may result in personal injury.

In addition to the warnings and cautions in this manual, use the following guidelines for safe operation of the unit.

- Read all instructions before using equipment.
- For your safety, the equipment is furnished with a properly grounded cord connector. Do NOT attempt to defeat the grounded connector.
- Install or locate the equipment only for its intended use as described in this manual. Do NOT use corrosive chemicals in this equipment.
- Do NOT operate this equipment if it has a damaged cord or plug, if it is not working properly, or if it has been damaged or dropped.
- This equipment should be serviced by qualified personnel only. Contact the nearest Authorized Service Agency for adjustment or repair.
- Do NOT block or cover any openings on the unit.
- Do NOT immerse cord or plug in water.
- Keep cord away from heated surfaces.
- Do NOT allow cord to hang over edge of table or counter.
- Do NOT clean this appliance with a water jet.
- This appliance is not to be used by persons (including children) with reduced physical, sensory, or mental capabilities, or lack of experience and knowledge unless they have been given supervision or instructions.
- Do not allow children to play with the appliance.

The following warnings and cautions appear throughout this manual and should be carefully observed.

- Turn the power off, unplug the power cord, and allow unit to cool down before performing any service or maintenance.
- The procedures in this manual may include the use of chemical products. These chemical products will be highlighted with bold face letters followed by the abbreviated HCS (Hazard Communication Standard). See Hazard Communication Standard manual for the appropriate Material Safety Data Sheets (MSDS).
- The equipment should be grounded according to local electrical codes to prevent the possibility of electrical shock. It requires a grounded receptacle with separate electrical lines, protected by fuses or circuit breaker of the proper rating.
- Bread may burn. Therefore toasters must not be used near or below curtains or other combustible walls and materials. Failure to maintain safe operating distances may cause discoloration or combustion.
- This appliance is NOT intended for use by persons (including children) with reduced physical, sensory, or mental capabilities, or lack of experience and knowledge, unless they have been given supervision or instruction concerning use of the appliance by a person responsible for their safety. Children should be supervised to ensure that they do NOT play with the appliance.

MUFFIN TOASTER MT-12

IMPORTANT SAFETY INFORMATION (continued)

WARNING

If the supply cord is damaged, it must be replaced by the manufacturer, its service agent, or a similarly qualified person in order to avoid a hazard.

WARNING

Do NOT modify the power supply cord plug. If it does not fit the outlet, have a proper outlet installed by a qualified electrician.

WARNING



This equipotentiality symbol shows external functional grounding connection.

WARNING

Do NOT use extension cords with this unit.

WARNING

Check with a qualified electrician if you are unsure if the appliance is properly grounded.

WARNING

Do NOT clean this appliance with a water jet.

WARNING

Provide at least 1 inch clearance all around the unit.

IMPORTANT

Keep these instructions for future reference. If the unit changes ownership, be sure this manual accompanies the equipment.

IMPORTANT

A.J. Antunes & Co. reserves the right to change specifications and product design without notice. Such revisions do NOT entitle the buyer to corresponding changes, improvements, additions, or replacements for previously purchased equipment.

CAUTION

All electrical service connections must be in accordance with local electrical codes and any other applicable codes.

WARNING

ELECTRICAL SHOCK HAZARD. FAILURE TO FOLLOW THE INSTRUCTIONS IN THIS MANUAL COULD RESULT IN SERIOUS INJURY OR DEATH.

- Electrical ground is required on this appliance.
- Do NOT modify the power supply cord plug. If it does not fit the outlet, have a proper outlet installed by a qualified electrician.
- Do NOT use an extension cord with this appliance.
- Check with a qualified electrician if you are unsure if the appliance is properly grounded.

SPECIFICATIONS

Electrical Specifications & Plug Configuration

Model & Mfg. No	Volt	Watts	Amps	Hz.	Plug Description
MT-12 9200131	200-240	3400	17.0	50/60	Marechal Pin & Sleeve 32 Amp., 220-250 Volt
MT-12 9200134	200-240	3400	17.0	50/60	L6-30P, 30 Amp., 250 Volt
MT-12 9200136	200-240	3400	17.0	50/60	HBL Pin & Sleeve 30 Amp., 250 Volt
MT-12 9200137	230	3400	14.8	50/60	IEC-309 230 Volt. Non- Molded Plug
MT-12 9200138	220-240	3400	14.8	50/60	IEC-309 16 Amp., 240 Volt Pin & Sleeve
MT-12 9200140	200-240	3400	17.0	50/60	IEC-309 32 Amp., 250 Volt Pin & Sleeve
MT-12 9200144	200-240	3400	17.0	50/60	L6-20P, 20 Amp., 250 Volt
MT-12 9200150	208-240	3400	16.3	50/60	Marechal Pin & Sleeve 32 Amp., 220-250 VAC (New Zealand)

MUFFIN TOASTER MT-12

SPECIFICATIONS (continued)

Dimensions

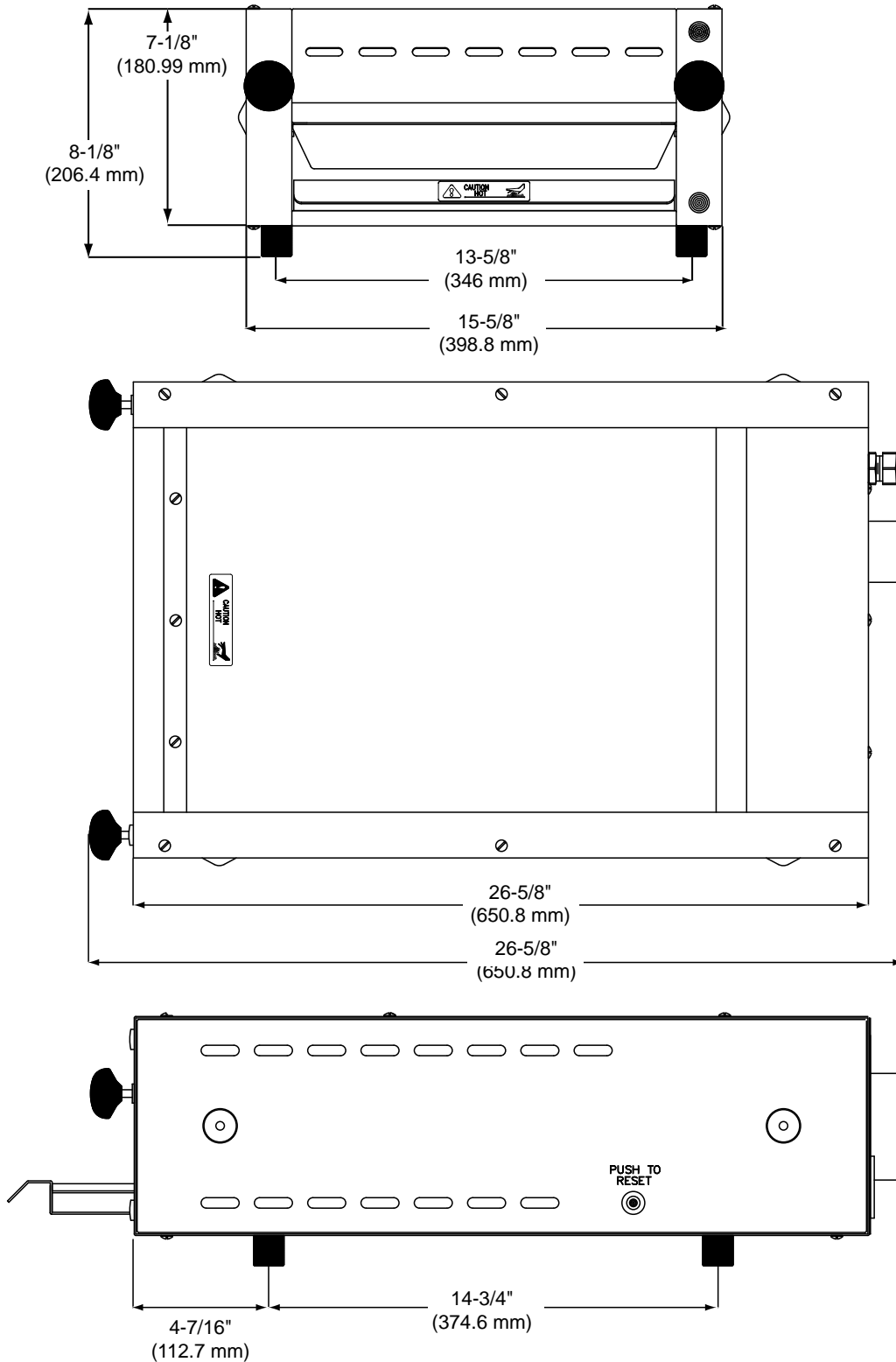

INSTALLATION

Unpacking

1. Remove unit and all packing materials from shipping carton.
2. Open the large box. It should contain the following items:
 - Muffin Toaster with Crumb Tray
 - Information Packet
3. Remove information packet.
4. Remove all packing materials and protective coverings from the unit.

NOTE: If any parts are missing or damaged, contact A.J. Antunes IMMEDIATELY at 1-630-784-1000 or in the U.S. or Canada, 1-800-253-2991 toll free.

5. Clean the toaster with a damp cloth. Remove and clean the crumb tray.

Location

When placing the toaster into service, pay attention to the following guidelines.

- Make sure the power is off and the unit is at room temperature before plugging in the power cord.
- Do NOT block or cover any openings on the unit.
- Do NOT immerse the power cord or plug in water.
- Keep the power cord away from heated surfaces.
- Do NOT allow the power cord to hang over edge of table or counter.

Plug the power cord into the appropriate power outlet. Refer to the specification plate for the proper voltage.

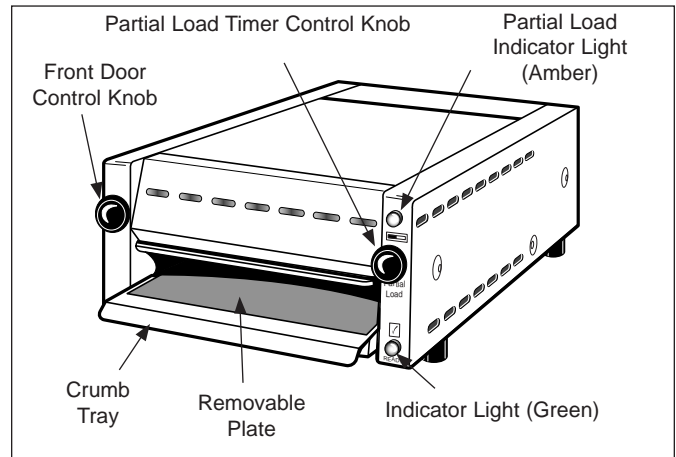

Figure 1. Muffin Toaster MT-12

⚠ CAUTION ⚠

All electrical service connections must be in accordance with local electrical codes and any other applicable codes.

MUFFIN TOASTER MT-12

OPERATION

1

A Turn Power Switch ON (Back of Unit)

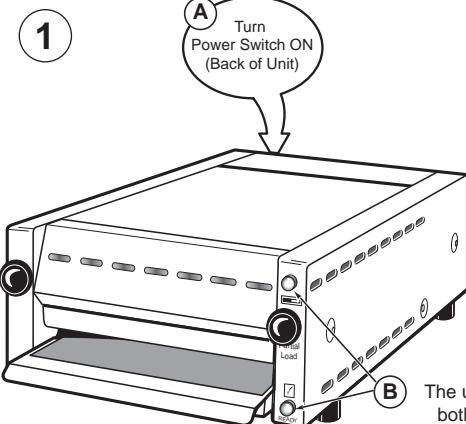

B The unit beeps twice and both lights blink twice. Allow the units to warm up for 30 minutes.



NOTE: If the self-test fails, a series of beeps will sound (see Diagnostic Flow Chart in Troubleshooting).

2

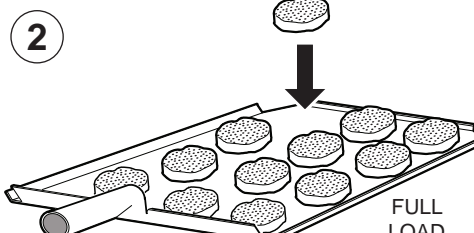

FULL LOAD

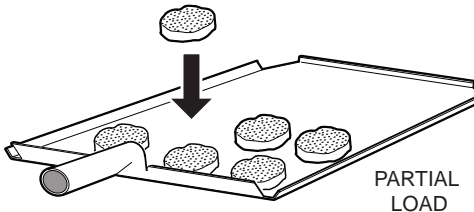

PARTIAL LOAD

NOTE: Always use a Spatula to insert and remove product from the unit. This is the only approved method for loading and unloading product into the toaster.

3

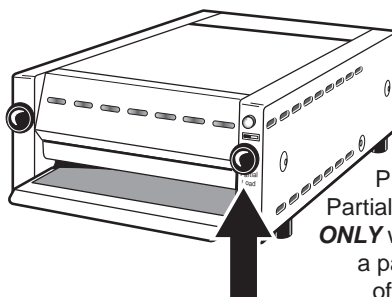

Press the Partial Load button **ONLY** when toasting a partial load of product.

NOTE: When the Amber light is on, a Partial Load Cycle is selected. When this light is off, a Full Load Cycle is selected.

4

Push the Front Door Control Knob **IN** to **UNLOCK** the door.

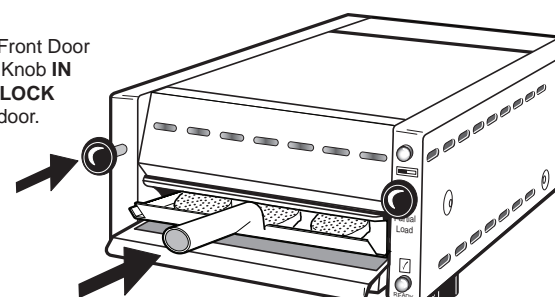

Next, slide the loaded Spatula into the unit.

⚠ CAUTION ⚠

The Crumb Tray and Removable Plate will be very hot when the unit is in operation. Do NOT use the Crumb Tray and Removable Plate as a means to load/unload product from the unit.

OPERATION (continued)

5

Pull the Front Door Control Knob **OUT** to **LOCK** the door.

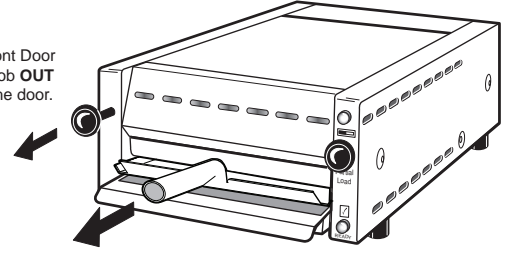

Next, Pull out the Spatula. The locked door keeps the product inside the toaster.

Do NOT toast product with the spatula inserted in the toaster!

8

A Push the Front Door Control Knob **IN** to **UNLOCK** and open the Front Door.

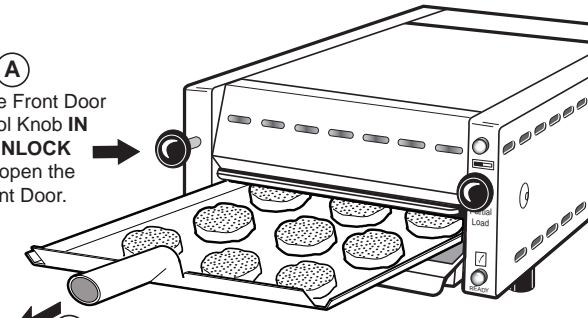

B Remove the Spatula out of the unit carefully.

6

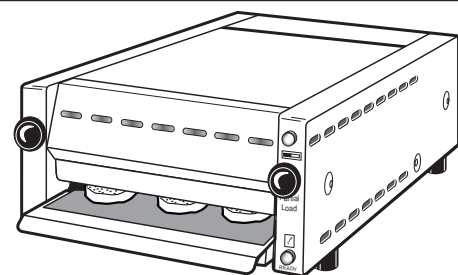

TOASTING TIMES:
 Full Load = 90 - 130 seconds
 Partial Load = 85 - 125 seconds



NOTE: The indicator lights blink and the Audio Signal beeps when the toast cycle completes.

9

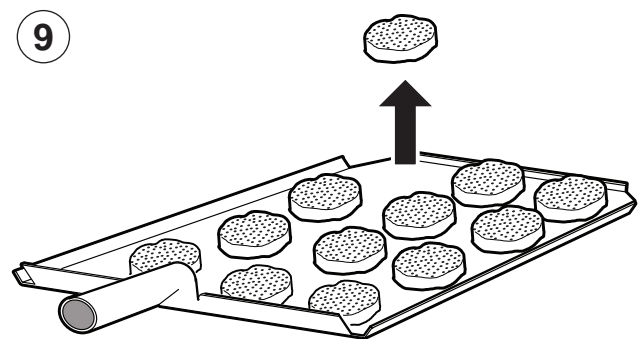

Remove product from the spatula. The unit is ready for another cycle.

7

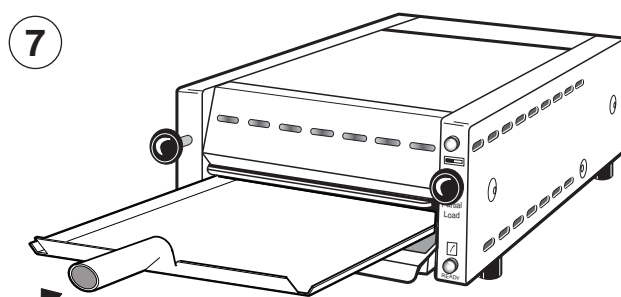

Carefully insert the Spatula into the unit. This transfers the product onto the spatula.

MUFFIN TOASTER MT-12

OPERATION (continued)

Hi-Limit Reset Button

A hi-limit thermostat will turn off electrical power to the heater and control circuits if the unit overheats. To reset the thermostat, allow sufficient time (about 45 minutes) for the unit to cool down, remove the cap and press the red reset button located on the side of the unit (Figure 2).

If the unit requires continuous resetting, contact your Authorized Service Agency.

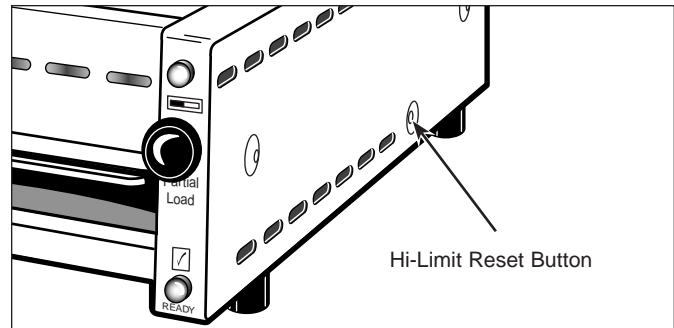

Figure 2. Hi-Limit Reset Button

MAINTENANCE

⚠ WARNING ⚠

Turn the power off, unplug the power cord, and allow the unit to cool down before performing any service or maintenance.

⚠ WARNING ⚠

Inspection, testing, and repair of electrical equipment should only be performed by qualified service personnel.

⚠ CAUTION ⚠

Chlorides or phosphates in cleaning agents (e.g. bleach, sanitizers, degreasers, or detergents) could cause permanent damage to stainless steel equipment.

The damage is usually in the form of discoloration, dulling of metal surface finish, pits, voids, holes, or cracks.

This damage is permanent and not covered by warranty. The following tips are recommended for maintenance of your stainless steel equipment:

- Always use soft, damp cloth for cleaning, rinse with clear water and wipe dry. When required, always rub in direction of metal polish lines.
- Stains and spots should be removed using a vinegar solution.
- Finger marks and smears should be rubbed off using soap and water.

⚠ CAUTION ⚠

If a chemical cleaner is used, be sure it is safe to use on cast aluminum. Observe all precautions and warnings on product label.

Maintenance Schedule

DAILY – CLEAN CRUMB TRAY

1. Turn the power switch to the off position. Unplug the power cord from the wall. Allow the toaster and plate to cool for at least 30 minutes.

NOTE: The muffin toaster may be hot. Make sure the toaster and plate are cool enough to handle before you begin cleaning.

2. Put on neoprene gloves. Remove the Spatula and set aside. Then, lift the Crumb Tray to remove it from the muffin toaster. Remove the Plate from the Crumb Tray.
3. Use a clean, sanitizer soaked towel to wipe the surface of the Plate.
4. Inspect the Plate for carbon build-up. Wipe the plate with a clean, damp cloth. IF the plate has excessive carbon build-up, apply McD Hi-Temp Grill Cleaner to the grill surface. Wipe the grill surface with a clean, sanitized grill cloth. Rinse the grill surface with water. Wipe the grill with a clean, sanitized towel to remove all cleaner residue.
5. Using a clean, sanitize towel, wipe the crumbs from the Crumb Tray. If necessary, wash the Crumb Tray and spatula at the 3 compartment sink.
8. Place the Plate back onto the Crumb Tray. Slide the Crumb Tray into the muffin toaster. Then place the Spatula into the muffin toaster

NOTE: The Plate is reversible. Rotate the Plate from side-to-side between cleanings. This extends the life of the Plate.

MAINTENANCE (continued)

MONTHLY – CHECK CALIBRATION

NOTE: You will need a stopwatch

1. Turn the power on.
2. Preheat the toaster for approximately 30 minutes. Close the front door and wait for the Audio Signal to beep. When the Audio Signal beeps, open the front door, then close it again. When the Audio Signal beeps a second time, open the front door.

WARNING

During this procedure, hot toasting surfaces will be exposed. Use extreme care to avoid personal injury.

3. Load 12 muffin halves into the toaster, close the front door, and start and start the stopwatch.
4. Check the time on the stopwatch when the Audio Signal beeps.

NOTE: The Audio Signal should beep and the Ready light should come on within 90 to 130 seconds.

5. Open the front door to stop the Audio Signal and to turn off the Ready light.
6. Remove muffins and reload with 6 muffin halves.
7. Close the front door, press and release the Partial Load Control Knob on the right front of the toaster until the Amber light is lit (Figure 1). Start the stopwatch.
8. Check the time on the stopwatch when the Audio Signal beeps.

NOTE: The Audio Signal should beep and the Ready light should come on within 85 to 125 seconds.

9. Open the front door to stop the Audio Signal and to turn off the Ready light.
10. If the times are correct, calibration is complete. If the times are not correct, adjust the timers located at the rear of the toaster (Figure 3)

NOTE: If the toasting time is still incorrect, contact the factory for assistance.

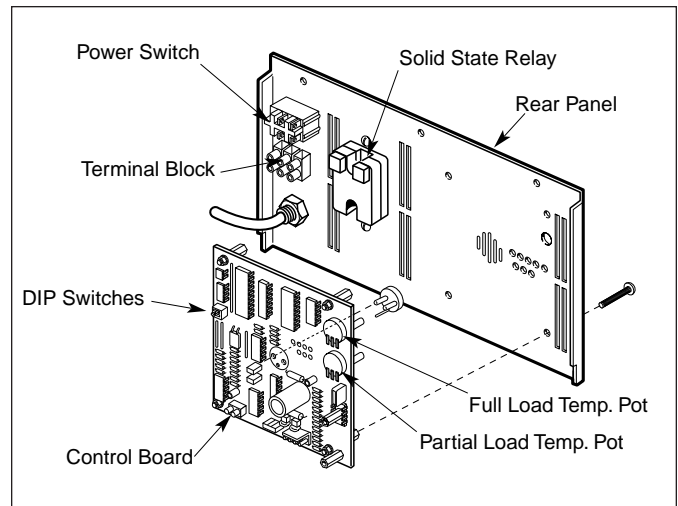

Figure 3. Adjusting Timer on Rear Panel Assembly

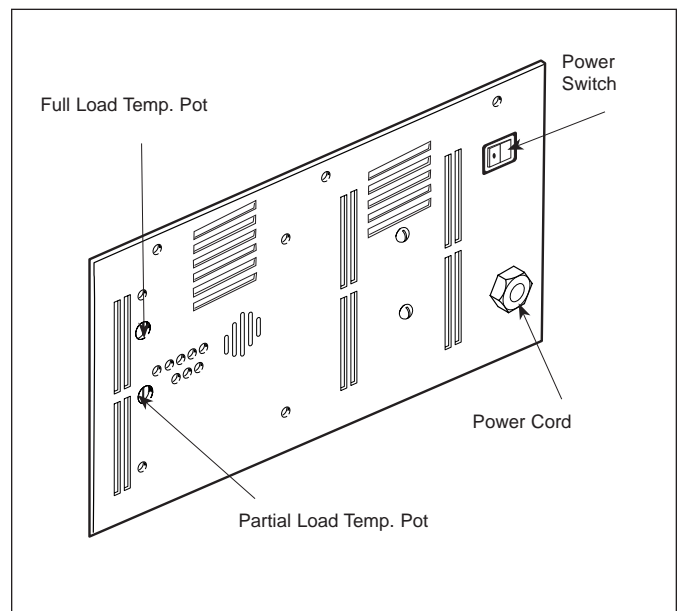

Figure 4. Rear Panel Assembly

MAINTENANCE (continued)

Function of Diagnostic LEDs

This section describes the Diagnostic LEDs and their functions. The Diagnostic LEDs are found at the back of the unit.

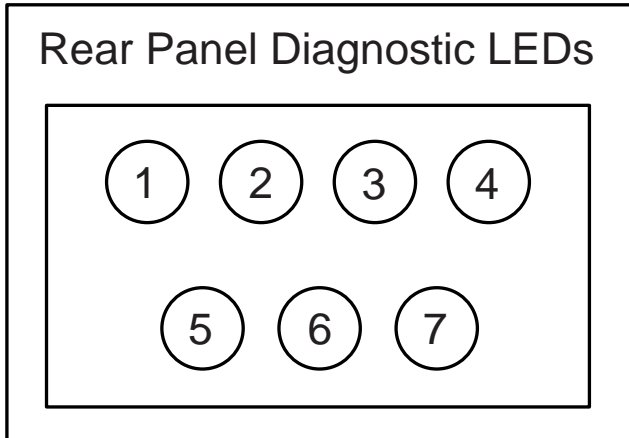

Figure 5. Diagnostic LEDs

- ① Full Load Switch Light - ON when the Full Load Switch is closed.
- ② Thermocouple Fault - ON when the thermocouple is disconnected or damaged. The toaster will not heat.
- ③ Solid State Relay On - ON when power is sent to the Solid State Relay. This LED pulses rapidly during operation.
- ④ Ready Light - ON when power is sent to the Ready Light.
- ⑤ Partial Load Switch - ON when the Partial Load Switch is closed.
- ⑥ Audio Signal - ON when power is sent to the Audio Signal.
- ⑦ Partial Load Light - ON when power is sent to the Partial Load Light.

Dip Switch Settings

Check your Control Board assembly to insure the Dip Switch settings are correct.

NOTE: Refer to the table below for a listing of Manufacturing numbers that use the 220 or 200 setting.

DO NOT USE HIGH SETTING.

Mfg. No.	200 or 220?	LO or High?
9200131	200	LO
9200134	200	LO
9200136	200	LO
9200137	220	LO
9200138	220	LO
9200140	200	LO
9200144	200	LO
9200150	200	LO

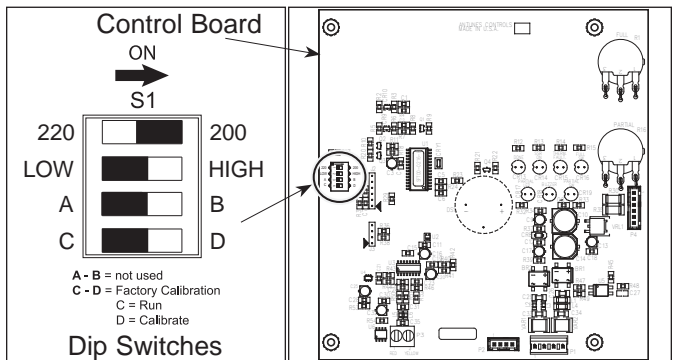

TROUBLESHOOTING

Diagnostic Flow Chart

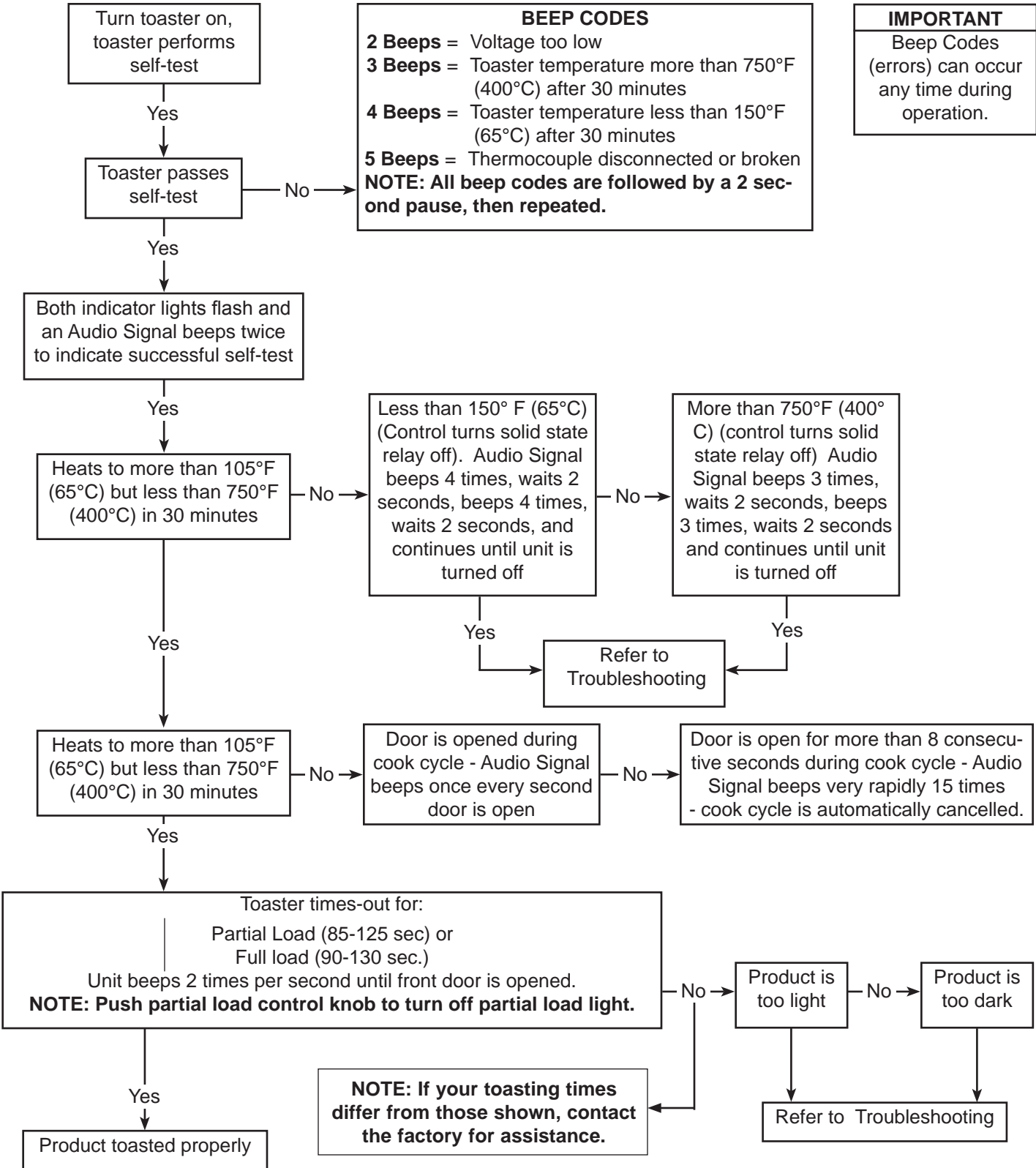

MUFFIN TOASTER MT-12

TROUBLESHOOTING (continued)

Problem	Possible Cause	Corrective Action
Toaster fails to operate (no heat, fan not running).	No power.	Make sure plug is locked into position and the power is on. Check building circuit breaker.
	Defective receptacle or power cord plug.	Plug into different receptacle. Replace cord.
	Loose wire connections.	Check and tighten all connections.
Not heating. Fan is working.	Hi-Limit thermostat is tripped or defective.	Turn toaster off for 20-30 minutes and then press the reset button. Replace Hi-Limit thermostat.
	Removable Plate is scuffed or scratched.	Replace Removable Plate.
	Removable Plate is too dull has excess carbon build-up.	Clean or replace Removable Plate.
Muffins too light or too dark at Audio Signal.	Using refrigerated or frozen muffins.	Muffins must be at room temperature before toasting. Allow a two day old rotation when using fresh muffins.
	Incorrect setting or regional preference dictates an adjustments of the timer. Approximate times are: Partial Load - 85-125 seconds Full Load - 90-130 seconds NOTE: If your toasting times differ from the values above, contact the factory for assistance.	Adjust full or partial load timers as needed.
Toaster does not operate properly when it is initially installed.	Toaster selected/shipped is not for the electrical service as this location.	Check toaster identification plate and refer to the Electrical Specifications of this Manual.
Toaster does not operate after the replacement of a Control Board.	One or more electrical service dip switches are improperly set for the locations electrical service.	Refer to the Dip Switch setting instructions provided in this manual.
Toaster will not operate (no heat and no fan operation) LED light on and Rocker Switch not lit.	Unit not turned on.	Confirm that the power is on.
	No Power. Circuit Breaker is off or tripped.	Reset Circuit Breaker. Contact your maintenance person or Authorized Service Agency if it trips again.
	Rocker Switch is inoperable.	Replace Rocker Switch.
	Poor plug to receptacle connection.	Lock plug into receptacle.
	Damaged or defective power cord.	Inspect power cord, replace if needed.
	Damaged or defected cord, plug, and/or pins.	Inspect plug and pins. Replace if needed.
	Damaged or defective receptacle.	Inspect receptacle. Call your electrician.
Loose electrical connection.	Contact your maintenance person or Authorized Service Agency for service.	

TROUBLESHOOTING (continued)

Problem	Possible Cause	Corrective Action
Toaster not heating (but fan is working).	Hi-Limit control is tripped or defective.	Turn toaster off for 30 minutes and then reset. If the Hi-Limit control trips repeatedly, contact your maintenance person or Authorized Service Agency.
	Loose/defective electronic connections.	Contact your maintenance person or Authorized Service Agency.
	Heating element/coil is broken/open.	
	Solid State Heater Relay is defective.	
	Control Board is defective.	
Fan not running but toaster is heating.	Fan is dirty or defective.	Clean or replace defective fan.
No Audio Signal, but Ready Light works.	Defective Audio Signal.	If Audio Diagnostic LED is on but there is no Audio Signal, replace the Audio Signal.
No Ready Light but Audio Signal works.	Defective Ready Light.	If Ready Light Diagnostic LED is on, but the Ready Light is not, replace the Ready Light.
No Audio Signal or Ready light on either Full or Partial Load cycles.	Control Board is defective.	Replace the Control Board.
Front Door will not open or close properly.	Door Push Rod is damaged.	Remove left cover and check Door Push rod for free movement of door. Straighten or replace rod as required.
		Have your maintenance person or Authorized Service Agency straighten or replace the Door Push Rod as required.
Heating element/coil is on continuously.	Defective Solid State Relay.	Contact your maintenance person or your Authorized Service Agency.
	Defective Control board.	
Only half the element coil is working.	Loose/defective electrical wiring connection.	Check wiring connections at element/coil
	Heating element/coil is broken/open	Replace the heating element/coil.

MUFFIN TOASTER MT-12

REPLACEMENT PARTS

Item	Part No.	Description	Qty.
1	0502891	Cover, Left	1
2	0800298	Rod, Door	1
3	0400283	Insulation, Side	2
4	0502868	Guide, Actuator	1
5	210K230	Bumper, 1 Leg Kit (pack of 4)	1
6	0502884	Pan, Base	1
7	2100132	Knob, Black	2
8	0020186	Front Door	1
9	05K2880	Plate, Removable	1
10	0502889	Crumb Tray	1
11	0502871	Retainer, Heater	1
12	7000113	Heating Assy. Kit, 200V (Mfg. No. 9200131, 9200134, 9200136, 9300140, 9200144, & 9200150)	1
	7000114	Heating Assy. Kit, 220V (9200137 & 9200138)	1
13	0502885	Panel, Face	1
14	0502881	Housing, Top	1
15	0502890	Cover, Right	1
16	4050180	Heat Sink	1
17	7000315	Relay, Solid State, Double Pole	1
18	4010137	Switch, Rocker (Power On/Off)	1
19	0400315	Strain Relief	1
20	7000464	Power Cord Assy (MT-12RR Mfg. No. 9200132) L6-30P 30 A 250 V Right Angle Twist Lock	1
	7000463	Power Cord Assy (MT-12RD Mfg. No. 9200136) Hubble Pin & Sleeve 30A 250V	1
	7000465	Power Cord Assy (MT-12RS Mfg. No. 9200134) L6-30P 30A 250V Straight Twist Lock	1
0700437		Power Cord Assy (MT-12HI Mfg. No. 9200138) Harmonized, IEC-309 16A 230V	1
0700587		Power Cord Assy (MT-12HB Mfg. No. 9200131) Harmonized, Marechal Pin & Sleeve 32A 230V Australia	1
0700588		Power Cord Assy (MT-12HJ Mfg. No. 9200140) Harmonized, IEC-309 32A 230V	1
0700552		Power Cord Assy (MT-12CU Mfg. No. 9200144) Japan, L6-20P 20A 250V Straight Twist Lock	1
0700699		Power Cord Assy (MT-12HM Mfg. No. 9210150) Harmonized, Marechal Pn & Sleeve 220-250 VACT 32 Amp (New Zealand)	1

Item	Part No.	Description	Qty.
	0700442	Power Cord Assy. (MT-12HI Mfg. No. 9200137) IEC-309 230 VAC Non-molded (China Only)	1
22	0502886	Panel, Rear	1
23	7000925	Control Board Kit	1
24	7000156	Audio Signal	1
25	050K128	Sensor Bracket Kit	1
26	0011036	Fan Assy.	1
27	4010103	Micro Switch	1
28	7000342	Indicator Light, Green & Amber	1
30	0800297	Rod, Partial	1
31	7000344	Hi-Limit Kit	1
32	0502873	Bracket, Hi-Limit	1
33	4010171	Switch, Push-Push	1
34	7000348	Thermocouple	1
35	406K006	Terminal Block Kit	1
36	4010170	Transformer	1
37	1000936	Label, Front Panel	1
38	0600113	Spring, Front Door	1
39	040P119*	Bushing, Shorty, 5/8"	1
40	7000401	Bushing & Retainer Kit	1
41	301P106*	Weld Nut	1
42	306P102*	Lockwasher, #6	1
43	306P115	Screw, #6-32 x 1"	1
44	306P123*	Screw, #6-32 x 7/8"	1
45	306P130*	Nut, Hex, KEPS, #6-32	1
46	308P103*	Screw, #8-32 x 1/4"	1
47	308P124*	Screw, #8-32 x 1/2", One-way	1
48	308P133*	Screw, #8-32 x 1/4"	1
49	308P143*	Nut, Hex, KEPS, #8-32	1
50	308P151*	Screw, SEMS, #8-32 x 5/16"	10
51	306P104*	Screw, #6-32 x 1/4"	1
52	300P117*	Washer, Retaining	1
53	040P111*	Bushing, Shorty, 1/2"	1
54	310P140*	Washer, Flat, #10	1
55	4060374	Ground Lug	1
56	0020995	Side Panel (RH) Weldment	1
57	0020996	Side Panel (LH) Weldment	1

* Available only in packages of 10.

REPLACEMENT PARTS (continued)

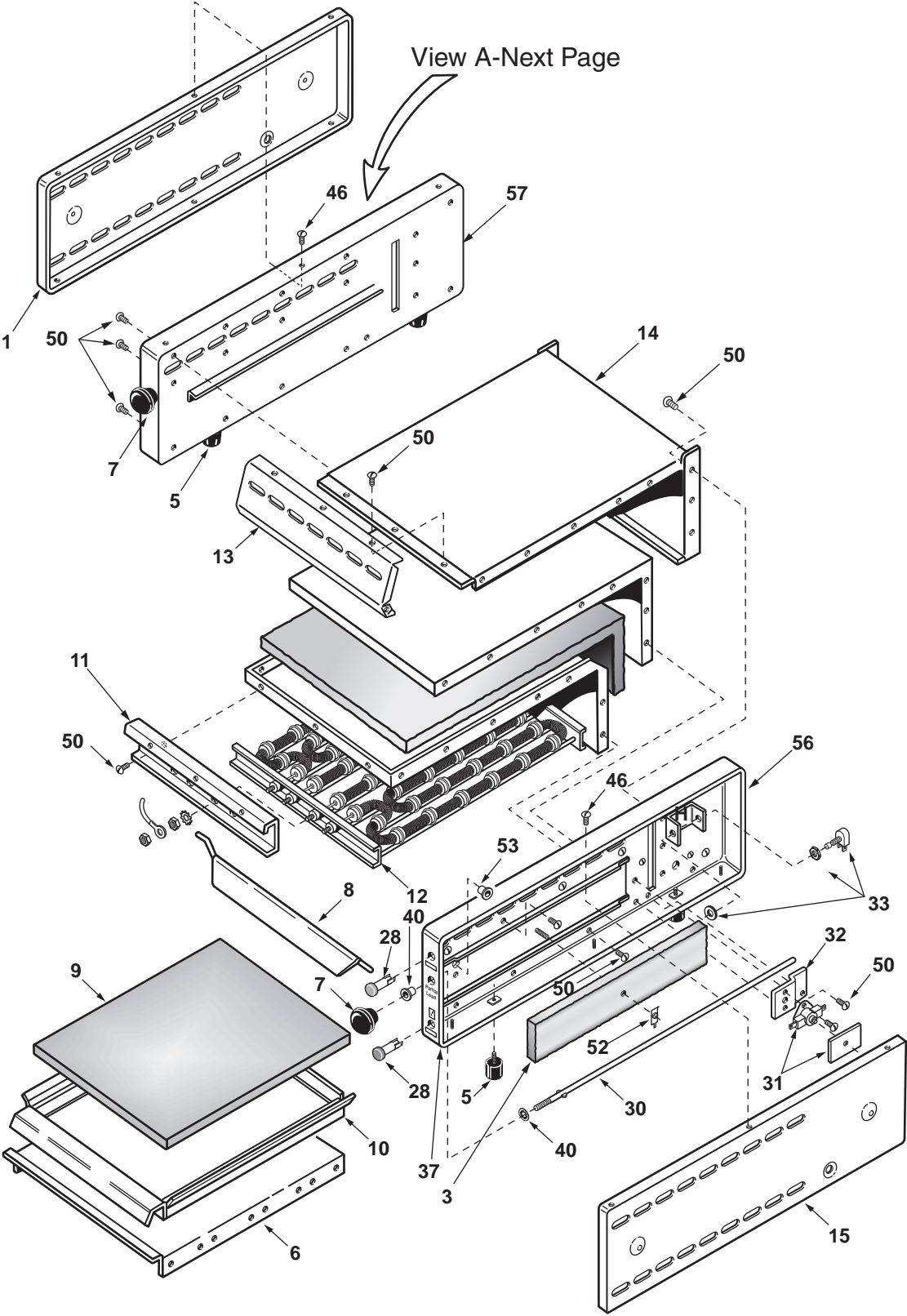

MUFFIN TOASTER MT-12

REPLACEMENT PARTS (continued)

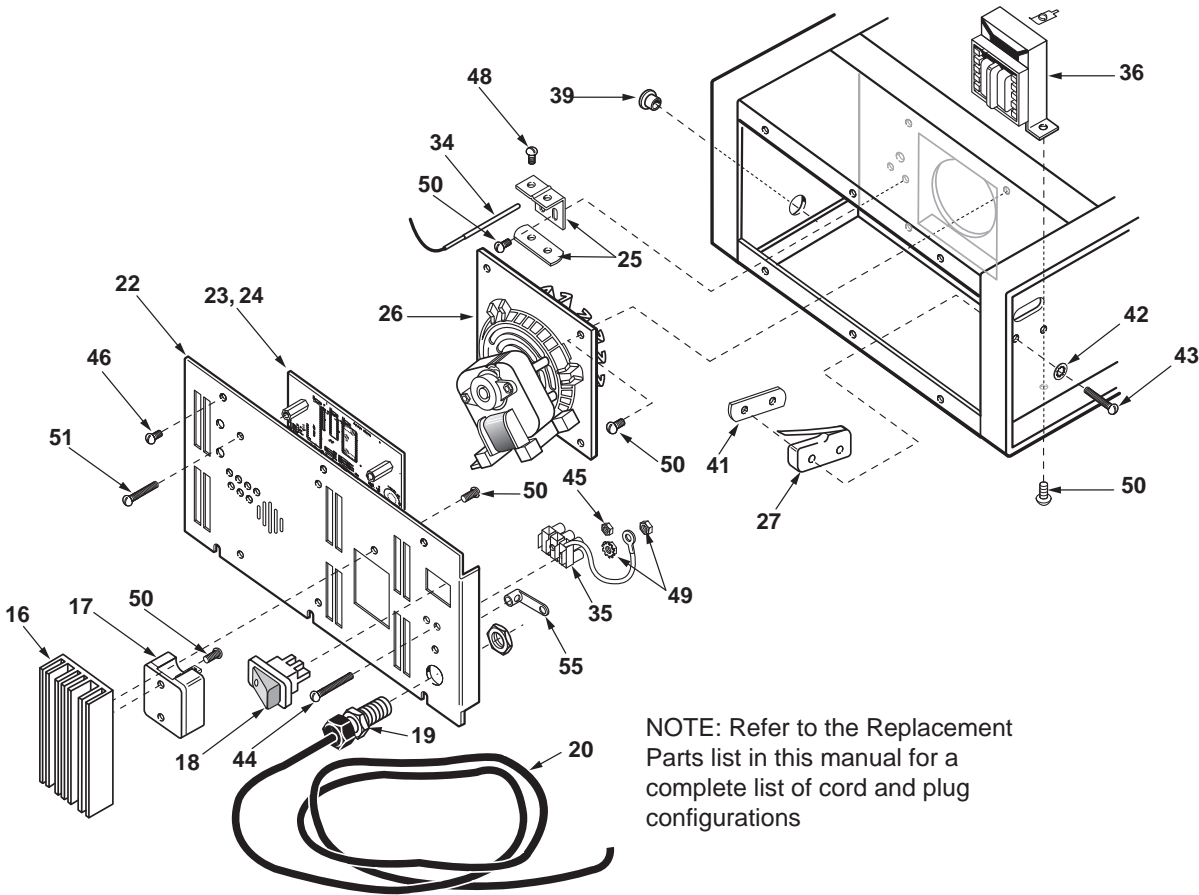

View A

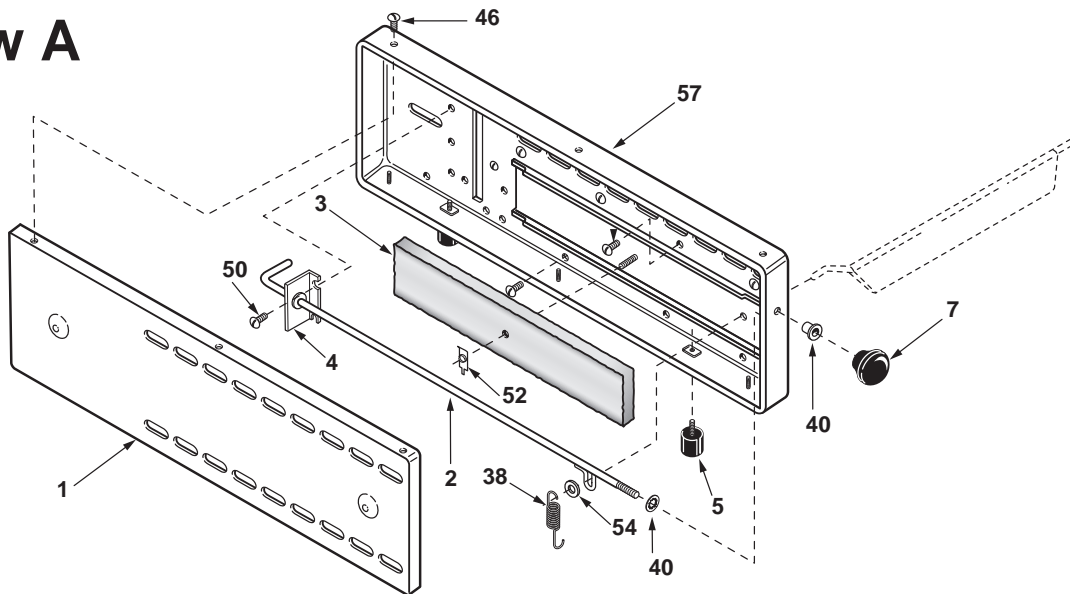

WIRING DIAGRAMS

